

MRE Series

Miniature Rectangular / #20 Contacts / .040" Dia. / 7.5 Amps



Receptacle MRE 14S-G



Plug MRE 14P-G

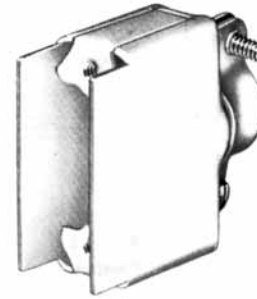

Hood MRE 14H

MRE Series plugs and receptacles are the accepted standard for rectangular-shaped, miniature, internal-type connectors. They embody all of the features expected of true miniaturization: maximum utility of space, extremely lightweight and unusually high

working voltage and current ratings. Their long life and trouble-free service continue to make them highly popular for use in aircraft, instrumentation and portable equipment. The MRE and MRA series share the same hoods, hardware and accessories.

Specification

Current Rating: 7.5 amps

No. of Contacts: 7, 8, 9, 11, 14, 18, 20, 21, 26, 34, 41, 42, 50, 75, 104

Pin Contacts: .040 dia., gold plated brass

Socket Contacts: Phosphor bronze plated gold.

Termination Types: .048 dia. solder cup is standard. It will accept up to #20 AWG stranded wire. Pin and Socket Contacts available with dip solder terminations, .025 Dia. Check Sales Dept. for lengths available.

Electrical Data: Meets high potential performance requirements of MIL-C-28748. Military versions are QPL'd to M28748/5 and M28748/6. The dielectric withstanding voltage is one minute at 1200

volts.

Dielectric: Brown mineral filled diallyl phthalate. Also available in gray glass filled diallyl phthalate, per MIL-M-14, SDG-F.

Polarization: Gold plated guides provide positive polarization. Polarized nickel-plated brass and/or passivated stainless steel jackscrews with anodized aluminum knobs are available.

Hoods: Anodized aluminum. May be applied to either plug or receptacle. Both top and side openings are available.

MRE Series

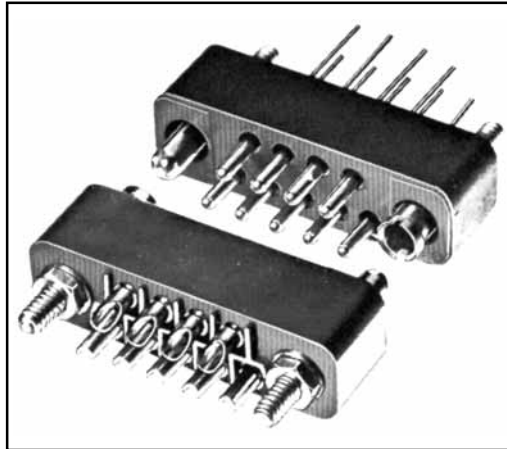

Termination Types

Solder Cup





.048 diameter solder cup is the standard termination for cable and panel mounting applications. It will accept up to #20 AWG stranded wire.

Dip Solder

For mounting on printed circuit boards, .025 diameter straight dip solder terminations (for Pin Contacts and Socket Contacts) are available. Consult the Sales Department for available lengths.

Guide Forms

3 Types of Guide Sockets are Available

Guide Socket Code Letter	Application	Actual Size Photo	
G*	The "G" type socket is the standard guide supplied. It has good physical strength and may be used electrically in a low current circuit or as a contact for ground leads.	 G Type For General Use Phosphor	
K	The "K" guide socket is an excellent electrical conductor. Its extra spring-tension provides a high normal force uniformly distributed along the surface of the engaged pilot guide, thus minimizing electrical resistance. The multivolt drop across extreme ends of the engaged pilot and socket guide is 10 mv. at 20 amps.	 K Type For High Electrical Conductivity Beryllium Copper	 Standard Guide Pin mates with all types Brass
N*	The high physical strength of the "N" guide socket allows a greater degree of forcible tightening against a mounting surface than is permitted by the other guide sockets. This feature is particularly desirable for mounting connectors which will be subject to severe vibration in service. "N" guides are not to be used electrically.	 N Type For extra Mechanical Strength Brass	

* For passivated stainless steel add SS suffix

Physical Data

HOW TO ORDER: To obtain "K" or "N" guides in place of the standard "G" type, substitute the desired socket style code letter ("K" or "N") for "G" in both the Plug and Receptacle Code Numbers. (See Code Numbers in table at right.)

Total No. of Contacts	Plug		Recept.		Weight Oz.		Total No. of Contacts	Plug		Recept.		Weight Oz.	
	Winchester Electronics Code No.	Winchester Electronics Code No.	No. Standard Contacts, 7.5 Amps (.048 dia. solder cup for #20 AWG)	No. Standard Contacts, 10 Amps (.052 dia. solder cup for #18 AWG)	Plug	Rec.		Winchester Electronics Code No.	Winchester Electronics Code No.	No. Standard Contacts, 7.5 Amps (.048 dia. solder cup for #20 AWG)	No. Standard Contacts, 10 Amps (.052 dia. solder cup for #18 AWG)	Plug	Rec.
7	MRE 7P-G	MRE 7S-G	7	none	.3	.3	26	MRE 26P-G	MRE 26S-G	26	none	.6	.5
8	MRE 8P-N	MRE 8S-N	8	none	.2	.2	34	MRE 34P-G	MRE 34S-G	34	none	.8	.7
9	MRE 9P-G	MRE 9S-G	9	none	.3	.3	41	MRE 41P-G	MRE 41S-G	41	none	.8	.6
11	MRE 11 P-G	MRE 11S-G	11	none	.3	.3	42	MRE 42P-G	MRE 42S-G	42	none	.9	.8
14	MRE 14P-G	MRE 14S-G	14	none	.3	.3	50	MRE 50P-G	MRE 50S-G	50	none	1.0	.9
18	MRE 18P-G	MRE 18S-G	18	none	.4	.4	75	MRE 75 P-G	MRE 75S-G	75	none	1.5	1.3
20	MRE 20P-G	MRE 20S-G	20	none	.5	.4	104	MRE 104P-JT	MRE 104S-G	104	none	3.3	2.2
21	MRE 21P-G	MRE 21S-G	21	none	.5	.5							

MRE Series

Outline

Dimensions are for reference only and are subject to change. Outline drawings on request.

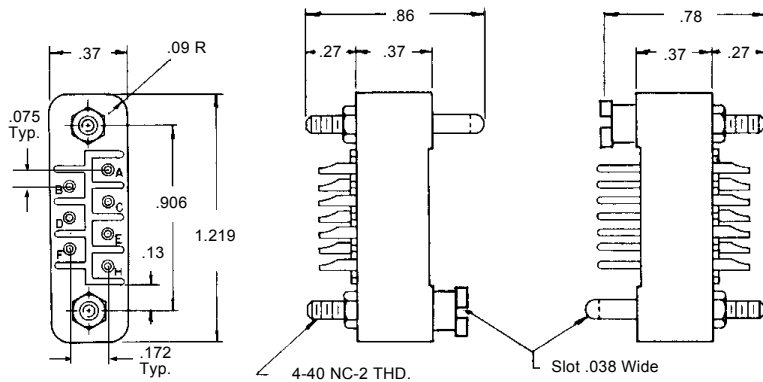

**Receptacle
MRE 7S-G**

**Plug
MRE 7P-G**

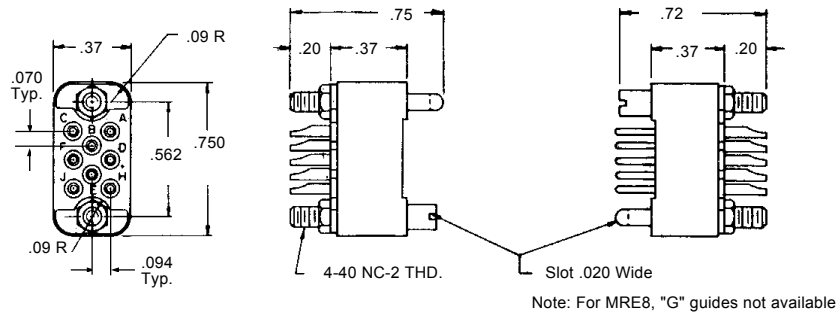

**Receptacle
MRE 8S-N**

**Plug
MRE 8P-N**

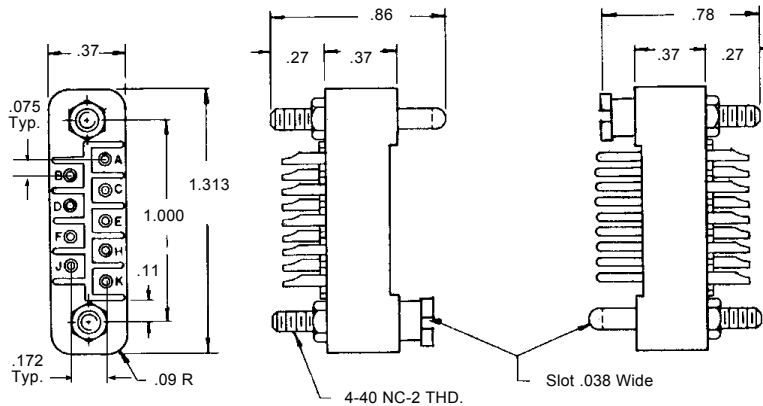

**Receptacle
MRE 9S-G**

**Plug
MRE 9P-G**

MRE Series

Outline

Dimensions are for reference only and are subject to change. Outline drawings on request.

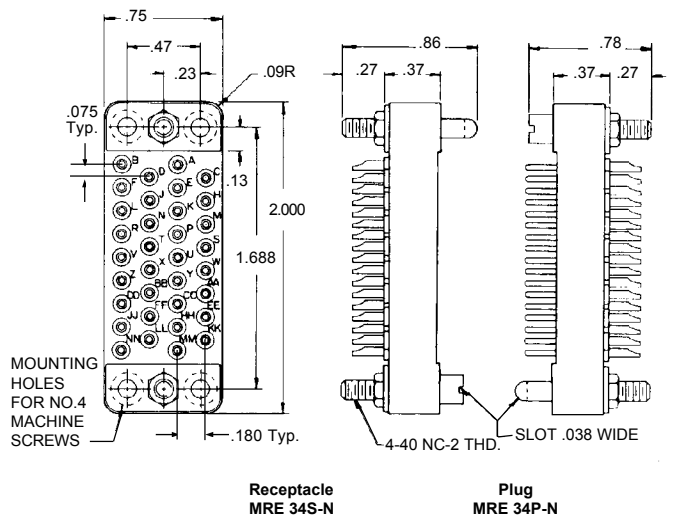
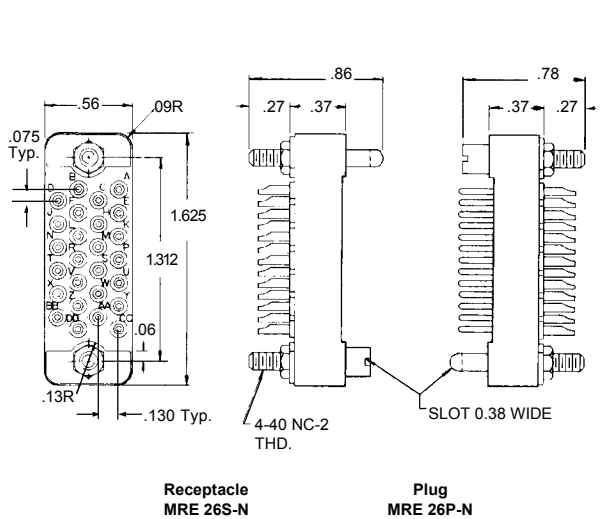
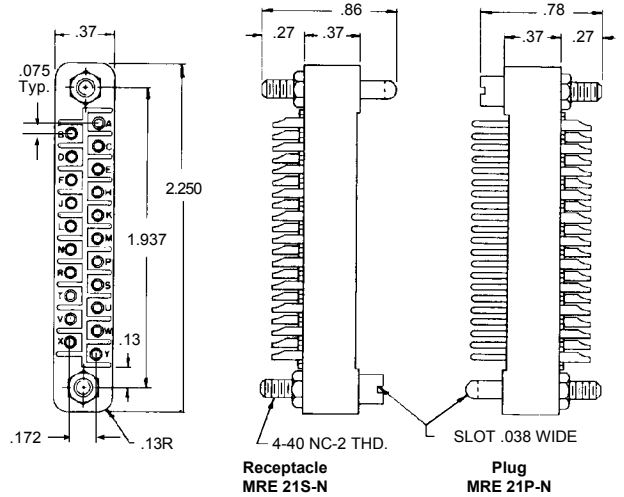
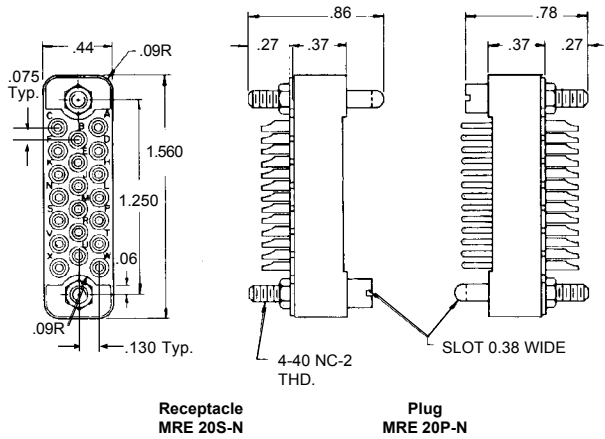
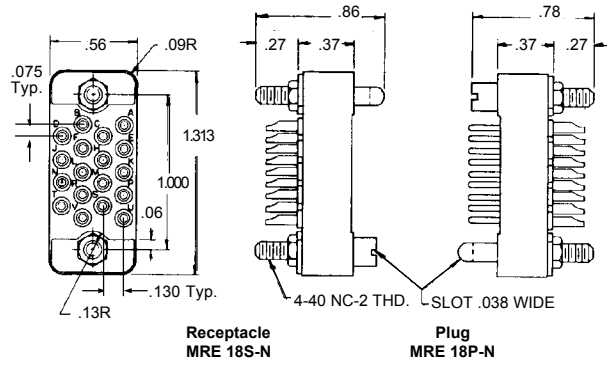
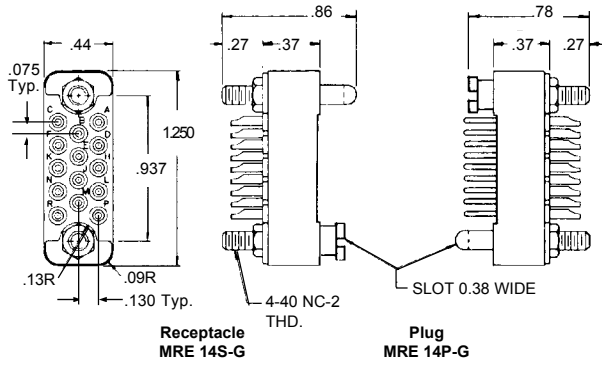

MRE Series

Outline

Dimensions are for reference only and are subject to change. Outline drawings on request.

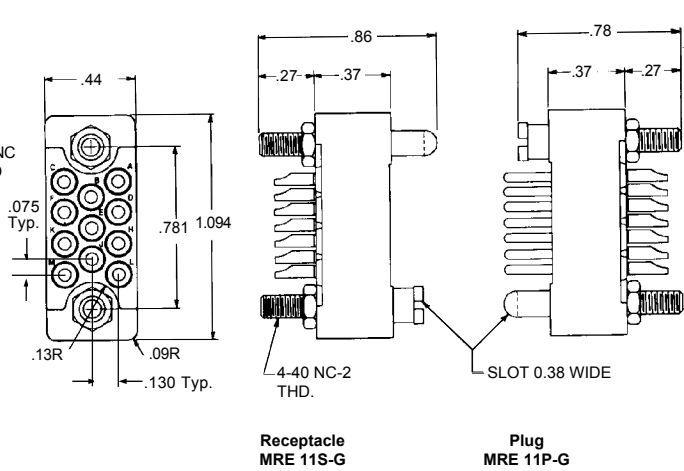
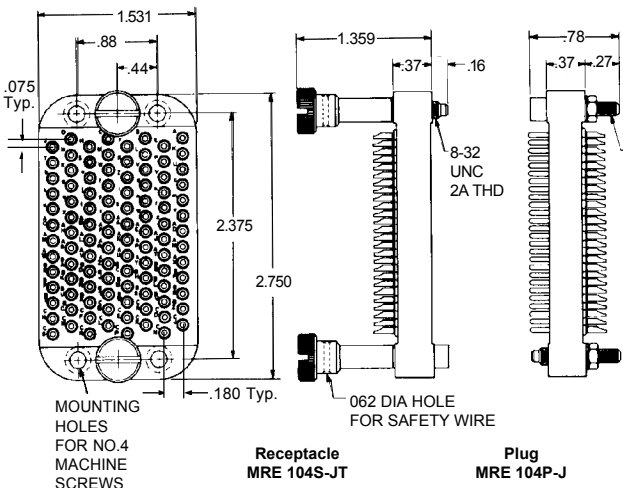
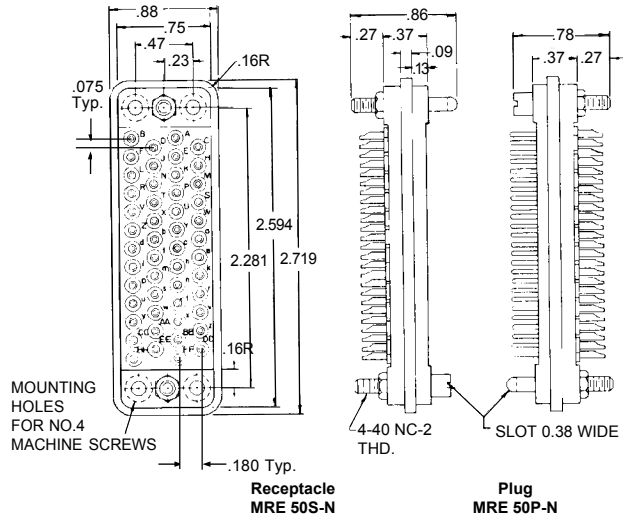
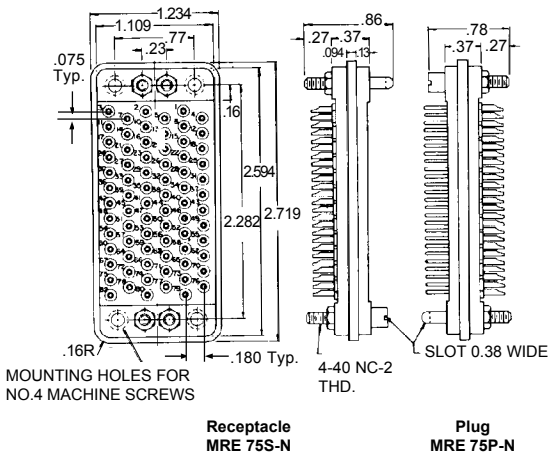
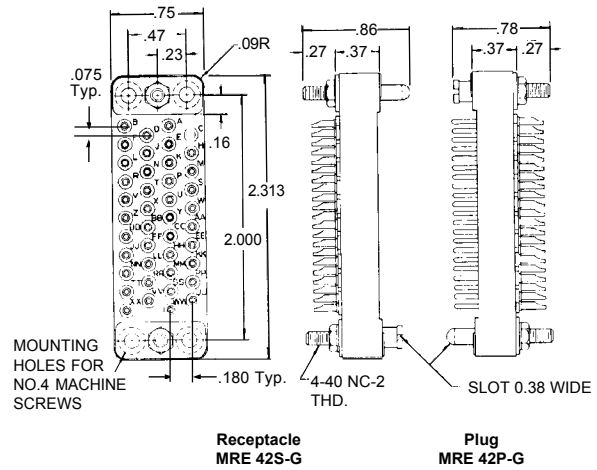
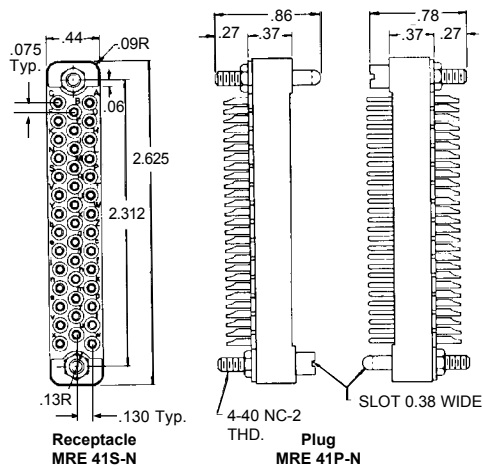

MRE Series

Polarized jackscrews give the ease and assurance of threaded positive coupling. The actuating side consists of two turnable screws, one male and one female, each with knurled and slotted knobs. On the mating half are the two fixed screws required to complete the locking action. When mated, the jackscrews may be locked with a safety wire through the hole in the self-locking pin (in the jackscrew shaft).

The drawings show the extension of the jackscrew knobs beyond a typical MRA connector and beyond the connector-and-hood assembly (center drawings). Dimensions given are constant for all connectors except as noted. Other dimensions applicable to various hood styles are detailed in the chart.

Jackscrews & Jacksockets

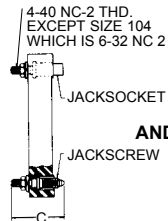

Connector with fixed Jackscrews.
Code designation: J

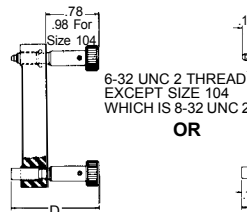

Mating connector half with turnable Jackscrews-with-Knobs.
Code designation: JT

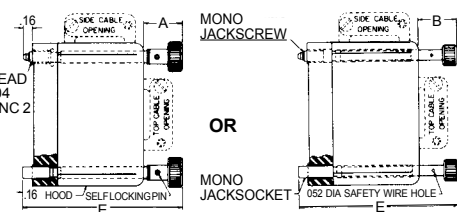

Mating connector half with Hood and turnable Long Jackscrews-with Knobs. Code designation: JTCH, JTCH1

Mating connector half with Hood and turnable Monojacks. Code designation: JTDH, JTDH1

Dimensions

Dimensions are for reference only and are subject to change. Outline drawings on request.

Connector Size	Dimension A				Dimension B				Dimen C	Dimen D	Dimension E				Dimension F			
	H	H1	H8	H9	H	H1	H8	H9			H	H1	H8	H9	H	H1	H8	H9
MRE 7	—	.58	.58	—	—	—	—	—	.80	1.31	—	2.09	2.09	—	—	—	—	
MRE 8	—	.5	.5	.5	—	—	—	—	.80	1.31	—	2.02	2.02	2.02	—	—	—	
MRE 9	—	.59	.58	.59	—	—	—	—	.80	1.31	—	2.41	2.09	2.41	—	—	—	
MRE 14	—	.59	.58	.59	—	—	—	—	.80	1.31	—	2.41	1.84	2.41	—	—	—	
MRE 18	—	.59	.83	.59	—	—	—	—	.80	1.31	—	2.41	2.09	2.41	—	—	—	
MRE 20	—	.59	.58	.59	—	—	—	—	.80	1.31	—	2.41	1.84	2.41	—	—	—	
MRE 21	.67	.59	.67	.59	—	—	—	—	.80	1.31	2.09	2.41	2.09	2.41	—	—	—	
MRE 26	.81	.59	.59	.59	—	—	—	—	.80	1.31	2.61	2.41	2.41	2.41	—	—	—	
MRE 34	.63	.63	.63	.63	.63	.63	.63	.63	.80	1.31	2.41	2.41	2.41	2.41	2.41	2.41	2.41	
MRE 41	.63	.63	—	—	—	—	—	—	.80	1.31	2.41	2.41	—	—	—	—	—	
MRE 42	.58	.58	.58	.58	.58	.58	.58	.58	.80	1.31	2.41	2.41	2.41	2.41	2.41	2.41	2.41	
MRE 50	.58	.58	.58	.58	.58	.58	.58	.58	.80	1.31	2.41	2.41	2.41	2.41	2.41	2.41	2.41	
MRE 75	.56	.56	.56	.56	.56	.56	.56	.56	.80	1.31	2.41	2.41	2.41	2.41	2.41	2.41	2.41	
MRE 104	.67	—	—	.67	.5	—	—	.5	.80	1.52	3.42	—	—	3.42	3.25	—	3.25	

New Monojacks Assemble and Disassemble With Remarkable Ease and Speed

To free the connector from the hood simply remove four screws. Monojacks may be used on miniature rectangular connectors with from

34 to 104 contacts. Molds have 2 center thru holes and 4 mounting holes.

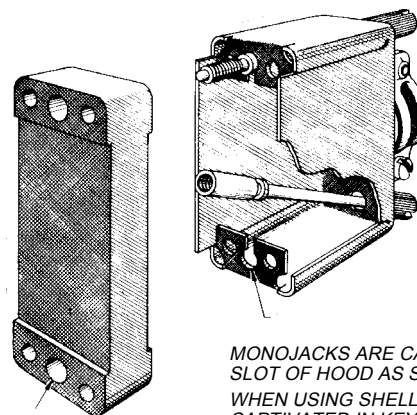

MOLDINGS HAVE STRAIGHT THRU HOLES

MONOJACKS ARE CAPTIVATED IN KEYHOLE SLOT OF HOOD AS SHOWN ABOVE.

WHEN USING SHELLS, MONOJACKS ARE CAPTIVATED IN KEYHOLE OF SHELL AND CLEARANCE HOLES ARE PLACED IN HOODS.

Outline Jackscrews & Jacksockets

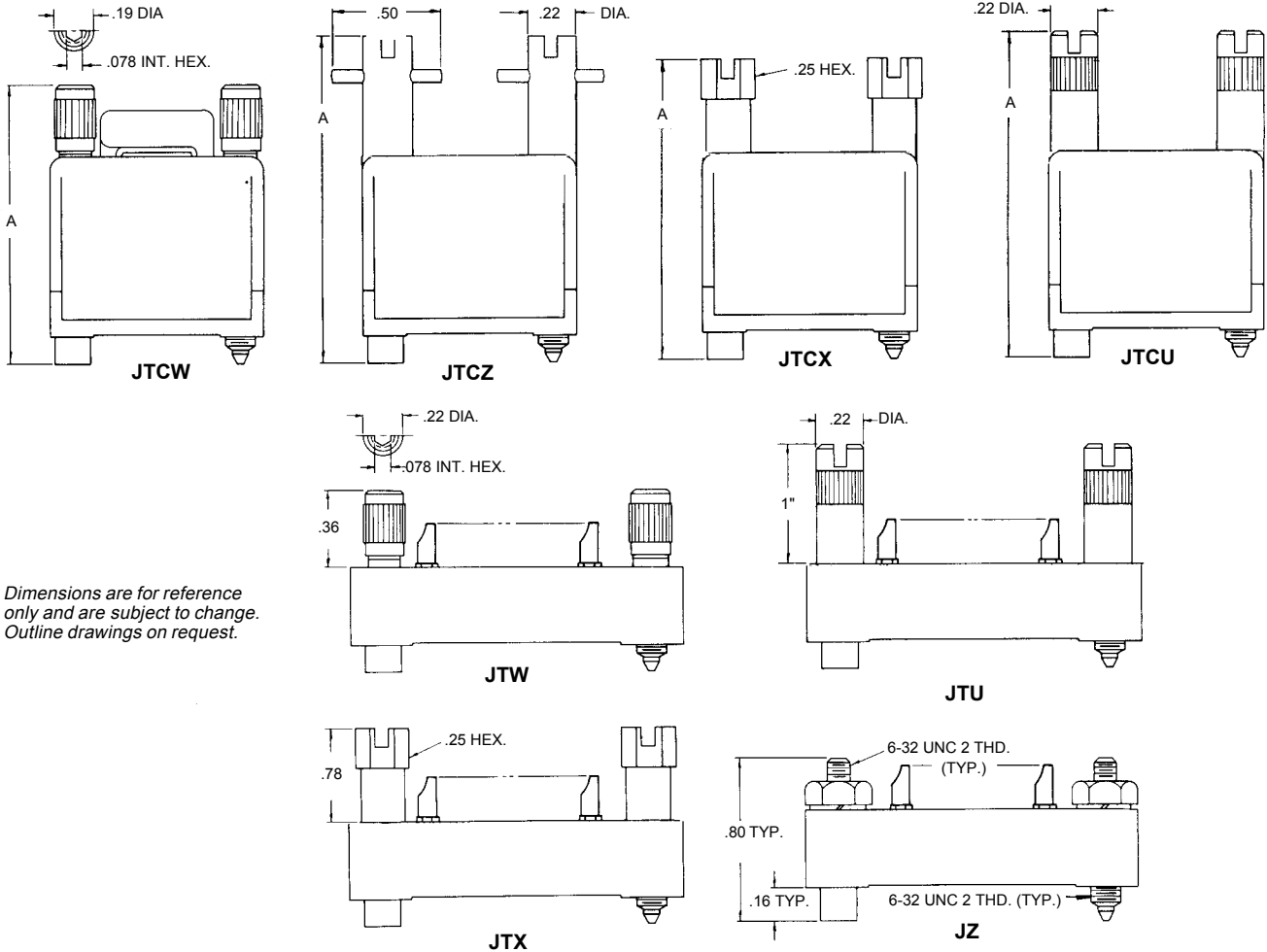

Dimensions are for reference only and are subject to change. Outline drawings on request.

Dimensions

All jackscrews and sockets are stainless steel, passivated, except for J & JTD which are nickel-plated brass. All knobs are aluminum, anodized except JTW and JTCW which are stainless steel, passivated.

Hood Type

Size	Type JTCW				Size	Type JTCU				Size	Type JTCX				Size	Type JTCZ			
	H	H1	H8	H9		H	H1	H8	H9		H	H1	H8	H9		H	H1	H8	H9
	Dimension A					Dimension A					Dimension A					Dimension A			
7	-	1.91	1.91	-	7	-	2.16	2.16	-	7	-	2.03	2.03	-	7	-	2.16	2.16	-
9	-	2.22	1.91	2.22	9	-	2.47	2.16	2.47	9	-	2.34	2.03	2.34	9	-	2.47	2.16	2.47
14	-	2.22	1.66	2.22	14	-	2.47	1.91	2.47	14	-	2.34	1.78	2.34	14	-	2.47	1.91	2.47
18	-	2.22	1.66	2.22	18	-	2.47	1.91	2.47	18	-	2.34	2.03	2.34	18	-	2.47	2.16	2.47
20	-	2.22	1.66	2.22	20	-	2.47	1.91	2.47	20	-	2.34	1.78	2.34	20	-	2.47	1.91	2.47
21	1.91	2.22	1.91	2.22	21	2.16	2.47	2.16	2.47	21	2.03	2.34	2.03	2.34	21	2.16	2.47	2.16	2.47
26	2.22	2.22	2.22	2.22	26	2.47	2.47	2.47	2.47	26	2.61	2.34	2.34	2.34	26	2.77	2.47	2.47	2.47
34	2.22	2.22	2.22	2.22	34	2.47	2.47	2.47	2.47	34	2.34	2.34	2.34	2.34	34	2.47	2.47	2.47	2.47
41	2.22	2.22	-	-	41	2.47	2.47	-	-	41	2.34	2.34	-	-	41	2.47	2.47	-	-
42	2.22	2.22	2.22	2.22	42	2.47	2.47	2.47	2.47	42	2.34	2.34	2.34	2.34	42	2.47	2.47	2.47	2.47
50	2.22	2.22	2.22	2.22	50	2.47	2.47	2.47	2.47	50	2.34	2.34	2.34	2.34	50	2.47	2.47	2.47	2.47
75	2.22	2.22	2.22	2.22	75	2.47	2.47	2.47	2.47	75	2.34	2.34	2.34	2.34	75	2.47	2.47	2.47	2.47

Outline Hoods- Formed Aluminum

Dimensions are for reference only and are subject to change. Outline drawings on request.

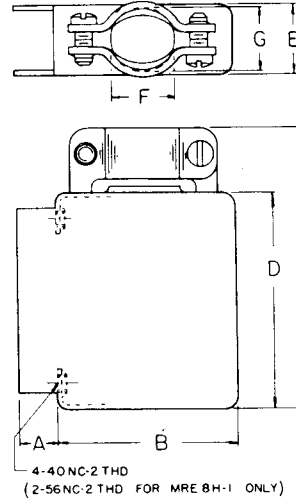
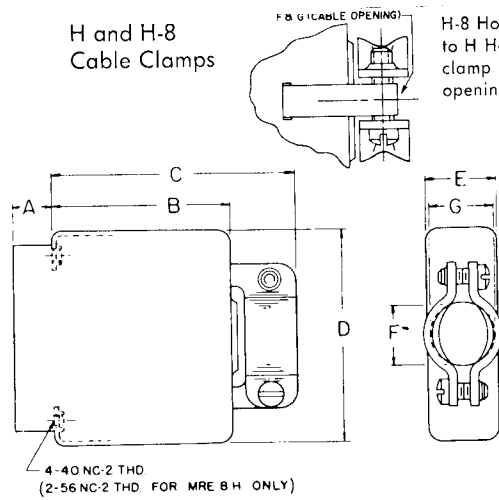

Dimensions

Top Cable Opening

Code No.	Dimensions					Cable Opening		Wt. Oz.	Fits Connector
	A	B	C	D	E	F	G		
MRE 7H*	.28	1	1.31	1.22	.44	.31D	-	.3	MRE 7 (P or S)
MRE 7H-8	.28	1	1.30	1.22	.44	.59	.31	.3	MRE 7 (P or S)
MRE 8H*	.28	1	1.31	.81	.44	.25D	-	.2	MRE 8 (P or S)
MRE 8H-8	.28	1	1.30	.81	.44	.31D	-	.2	MRE 8 (P or S)
MRE 9H*	.28	1	1.31	1.31	.44	.31D	-	.3	MRE 9 (P or S)
MRE 9H-8	.28	1	1.30	1.31	.44	.59	.31	.3	MRE 9 (P or S)
MRE 14H*	.28	.75	1.19	1.25	.5	.44D	-	.3	MRE 14 (P or S)
MRE 14H-8	.28	.75	1.05	1.25	.5	.59	.38	.3	MRE 14 (P or S)
MRE 18H*	.28	.75	1.19	1.31	.63	.44D	-	.4	MRE 18 (P or S)
MRE 18H-8	.28	.75	1.25	1.31	.63	.63	.44	.4	MRE 18 (P or S)
MRE 20H*	.25	.75	1.19	1.56	.5	.44D	-	.3	MRE 20 (P or S)
MRE 20H-8	.25	.75	1.05	1.56	.5	.66	.38	.3	MRE 20 (P or S)
MRE 21H	.28	.91	1.34	2.25	.44	.59	.31	.5	MRE 21 (P or S)
MRE 21H-8	.28	.91	1.36	2.25	.44	.78	.31	.5	MRE 21 (P or S)
MRE 26H	.28	1.28	1.72	1.63	.64	.59	.38	.4	MRE 26 (P or S)
MRE 26H-8	.28	1.28	1.78	1.63	.64	.78	.44	.4	MRE 26 (P or S)
MRE 34H	.28	1.25	1.69	2	.83	.66D	-	.6	MRE 34 (P or S)
MRE 34H-8	.28	1.25	1.75	2	.83	1.06	.56	.6	MRE 34 (P or S)
MRE 41H	.28	1.25	1.69	2.63	.5	.66	.44	.6	MRE 41 (P or S)
MRE 42H	.09	1.30	1.73	2.31	.83	.63D	-	.7	MRE 42 (P or S)
MRE 42H-8	.09	1.30	1.80	2.31	.83	1.06	.56	.7	MRE 42 (P or S)
MRE 50H	.09	1.30	1.73	2.59	.83	.63D	-	.8	MRE 50 (P or S)
MRE 50H-8	.09	1.30	1.80	2.59	.83	1.06	.56	.8	MRE 50 (P or S)
MRE 75H	.09	1.31	1.75	2.59	1.19	.63	.88	1.0	MRE 75 (P or S)
MRE 75H-8	.09	1.31	1.86	2.59	1.19	1	.88	1.0	MRE 75 (P or S)
MRA104H	FOR DIMENSIONS SEE PAGE RP/36								

* H Hoods for MRE 7, 8, 9, 14, 18 and 20 will not accept JTC hardware. Use H8 hoods.

Side Cable Opening

Code No.	Dimensions					Cable Opening		Wt. Oz.	Fits Connector
	A	B	C	D	E	F	G		
MRE 7H-1	.28	1.28	1.53	1.22	.44	.31D	-	.3	MRE 7 (P or S)
MRE 8H-1	.28	1.28	1.13	.81	.44	.25	-	.2	MRE 8 (P or S)
MRE 8H-9	.28	1.28	1.13	.81	.44	.59	.31	.2	MRE 8 (P or S)
MRE 9H-1	.28	1.28	1.63	1.31	.44	.31D	-	.3	MRE 9 (P or S)
MRE 9H-9	.28	1.28	1.61	1.31	.44	.59	.31	.3	MRE 9 (P or S)
MRE 14H-1	.28	1.28	1.69	1.25	.5	.38D	-	.3	MRE 14 (P or S)
MRE 14H-9	.28	1.28	1.55	1.25	.5	.59	.38	.3	MRE 14 (P or S)
MRE 18H-1	.28	1.28	1.75	1.31	.63	.44D	-	.3	MRE 18 (P or S)
MRE 18H-9	.28	1.28	1.81	1.31	.63	.69	.44	.3	MRE 18 (P or S)
MRE 20H-1	.28	1.28	2	1.56	.5	.38D	-	.3	MRE 20 (P or S)
MRE 20H-9	.28	1.28	1.86	1.56	.5	.66	.38	.3	MRE 20 (P or S)
MRE 21H-1	.28	1.28	2.69	2.25	.44	.53	.25	.5	MRE 21 (P or S)
MRE 21H-9	.28	1.28	2.72	2.25	.44	.78	.31	.5	MRE 21 (P or S)
MRE 26H-1	.28	1.28	2.06	1.63	.64	.59	.38	.4	MRE 26 (P or S)
MRE 26H-9	.28	1.28	2.13	1.63	.64	.78	.44	.4	MRE 26 (P or S)
MRE 34H-1	.28	1.25	2.42	2	.83	.66D	-	.6	MRE 34 (P or S)
MRE 34H-9	.28	1.25	-	2	.83	.81	.56	.6	MRE 34 (P or S)
MRE 41H-1	.28	1.25	3.06	2.63	.5	.66	.44	.6	MRE 41 (P or S)
MRE 42H-1	.09	1.30	2.73	2.31	.83	.63	.5	.7	MRE 42 (P or S)
MRE 42H-9	.09	1.30	-	2.31	.83	.84	.56	.7	MRE 42 (P or S)
MRE 50H-1	.09	1.30	3.02	2.59	.83	.63	.5	.8	MRE 50 (P or S)
MRE 50H-9	.09	1.30	-	2.59	.83	1.06	.56	.8	MRE 50 (P or S)
MRE 75H-1	.09	1.31	3.02	2.59	1.19	.63	.88	1.0	MRE 75 (P or S)
MRE 75H-9	.09	1.31	-	2.59	1.19	1	.88	1.0	MRE 75 (P or S)
MRA104H-9	FOR DIMENSIONS SEE PAGE RP/36								

MRE Series

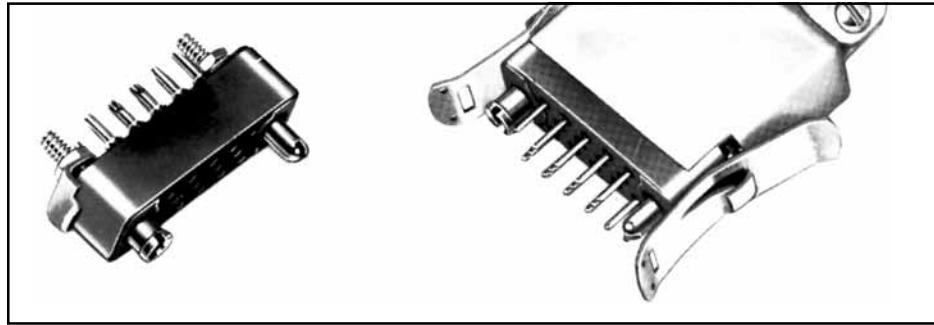

Lock Tabs (MRE-V shown)

Lever & Pivot Assemblies (MRE-VL shown)

Hoods - Locking

Vibration Locks*

Lever & Pilot Assembly	Lock Tabs (See Note)	Used on Connectors
MRE-VL	MRE-V	MRA 9, 14, 20, 34, 41, 42, 66
MRE-VL2	MRE-V2	MRE 50, 75

Vibration locks offer simplicity of design and positive locking in excess of 50G shock impact and 10G vibration acceleration. Mating halves automatically lock when engaged. To unlock, depress the levers. Drilled holes in the levers

are provided for safety wiring. Vibration locks are available separately for assembly on connectors now in service. Each code number indicates two units: two levers with two pivots, and two lock tabs.

*US Patent Number 2760174

Note: When panel mounting the lock-tab half of a MRE 34, MRE 42 or MRE 50 and MRE 66 connector, flat washers (.033 minimum thickness) should be used on the mounting screws to shim the molding away from the panel.

Dimensions / Outline Mounting Brackets

Code No.	DIMENSIONS							Wt. Oz.	
	A	B	C	D	E	F	G		
MRE 50B	1.06	.688	3.031	3.44	.13	.28	.78	.128 Dia 3 Holes (No. 4 Mounting Screw)	.4
MRE 75B	1.48	1.047	3.062	3.56	.14	.30	1.14	.150 Dia 3 Holes (No. 6 Mounting Screw)	.6

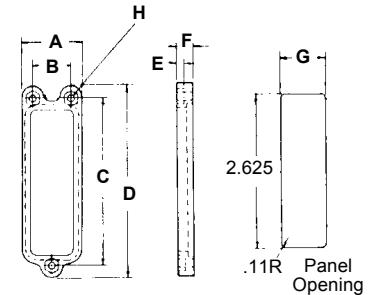

MRE 50 and MRE 75 connectors use the standard MRE 50 and MRE 75 mounting brackets

Dimensions / Outline Pre-Shaped Nylon Potting Forms

Dimensions are for reference only and are subject to change. Outline drawings on request.

Each form matches the back opening contour of its appropriate shell, and stays easily in place during the potting operation. Of negligible weight, it need not be removed from

the connector after potting. Because of floating contacts, connector halves should always be engaged during the potting operation to preserve contact alignment.

Potting Form Code No.	Fig.	Dimensions	
		A	B
MRE 7 FM	3	.62	.43
MRE 8 FM	2	.46	.43
MRE 9 FM	3	.77	.43
MRE 14 FM	2	.93	.49
MRE 18 FM	2	.87	.61
MRE 20 FM	2	1.12	.49
MRE 21 FM	3	1.68	.43
MRE 26 FM	2	1.18	.61
MRE 34 FM	1	1.38	.80
MRE 41 FM	2	2.18	.49
MRE 42 FM	1	1.69	.80
MRE 50 FM	1	1.97	.80
MRE 75 FM	1	1.98	1.16

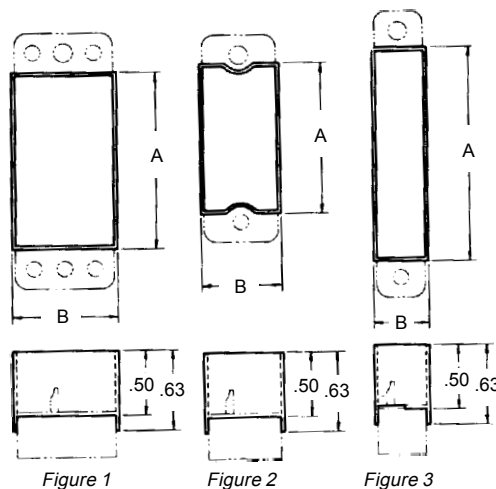

Ordering Information

Omit steps not required

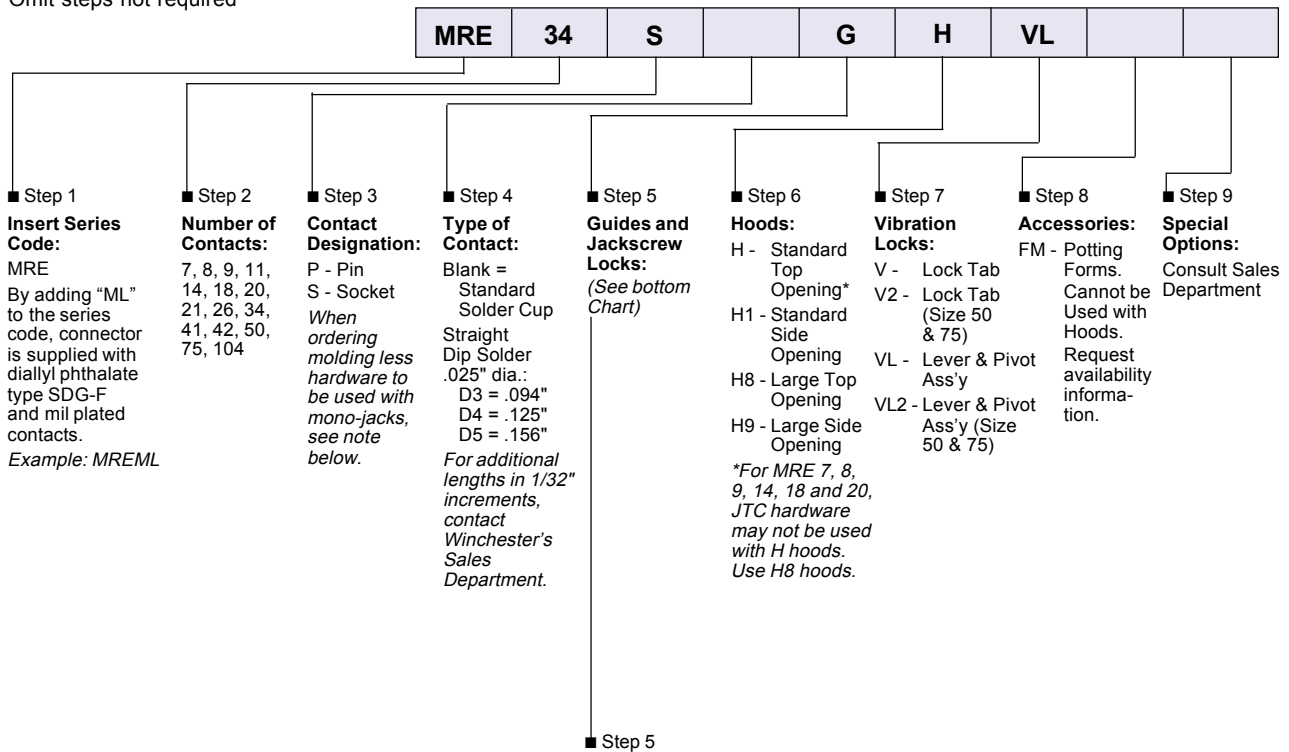

■ Step 1

Insert Series Code:
MRE
By adding "ML" to the series code, connector is supplied with diallyl phthalate type SDG-F and mil plated contacts.
Example: MREML

■ Step 2

Number of Contacts:
7, 8, 9, 11, 14, 18, 20, 21, 26, 34, 41, 42, 50, 75, 104

■ Step 3

Contact Designation:
P - Pin
S - Socket
When ordering molding less hardware to be used with mono-jacks, see note below.

■ Step 4

Type of Contact:
Blank = Standard Solder Cup
Straight Dip Solder
.025" dia.:
D3 = .094"
D4 = .125"
D5 = .156"
For additional lengths in 1/32" increments, contact Winchester's Sales Department.

■ Step 5

Guides and Jackscrew Locks:
(See bottom Chart)

■ Step 6

Hoods:
H - Standard Top Opening*
H1 - Standard Side Opening
H8 - Large Top Opening
H9 - Large Side Opening
**For MRE 7, 8, 9, 14, 18 and 20, JTC hardware may not be used with H hoods. Use H8 hoods.*

■ Step 7

Vibration Locks:
V - Lock Tab
V2 - Lock Tab (Size 50 & 75)
VL - Lever & Pivot Ass'y
VL2 - Lever & Pivot Ass'y (Size 50 & 75)

■ Step 8

Accessories:
FM - Potting Forms.
Cannot be Used with Hoods.
Request availability information.

■ Step 9

Special Options:
Consult Sales Department

■ Step 5

Guides

- *G Phosphor Bronze Cylindrical Guides*
 - K Beryllium Copper Cylindrical Guides
 - *N Brass Cylindrical Guides*
- Guides are not recommended for Size 104
"P" indicates two guide pins or two jackscrews (Ex. JTCP)
"S" indicates two guide sockets or two jacksockets. (Ex. GS)

Jackscrew Locks

- ***J Polarized Fixed Jackscrew and Jacksocket
- JT Polarized Short Turning Jackscrew and Jacksocket
- JTC Polarized Long Turning Jackscrew and Jacksocket
- *** JTD Polarized Long Turning Mono-Jackscrew and Mono-Jacksocket for Sizes 34, 42, 50, 75, and 104 only.

- **JZ Same as J but with 6-32 mtg. thd. (Not available 5-3, 8) (Std. on 104)
- **JTW Same as JT but with knurled round knob with internal hex (not avail. 5-3, 8, 104)
- **JTU Same as JT but with knurled round knob with screwdriver slot (not avail. 5-3, 8, 104)
- **JTX Same as JT but with hex knob (not avail. 5-3, 8, 104)
- **JTCW Same as JTC but with knurled round knob with internal hex (not avail. 5-3, 8, 104)
- **JTCU Same as JTC but with knurled round knob with screwdriver slot (not avail. 5-3, 8, 104)
- **JTCX Same as JTC but with hex knob (not avail. 5-3, 8, 104)
- **JTCZ Same as JTC but with prybar knob.
- ** *Request availability information.*
- *** *Material: Nickel-plated brass - standard*
Example: MRE34SJTDBH8

** For passivated stainless steel add SS suffix (Example: MRE34SSGS)*

Mounting Note: Connectors MRE 41, MRE 26, and smaller use guides for mounting in a hood or on a panel. Connectors MRE 34, MRE 42, MRE 50, MRE 75, use four #4 machine screws, in addition to guides, for mounting in a hood or on a panel.

Note: When ordering hoods, hardware and connectors separately for use with JTD Monojacks, connectors must be ordered as follows:

Pin connector = MRE34P8, MRE42P8, etc.

Socket connector = MRE34S8, MRE42S8, etc.

The number "8" indicates special housing for use with the JTD Monojack hardware (available on sizes 34, 42, 50, 66, 75 and 104).